



Elderfield & Hall, Inc.,

www.kooltools.com

10901 McBride Lane, Knoxville TN, 37932.

Phone: 865.671.7682. Fax: 865.671.7686.

Email: bob@kooltools.com

X-tra Long Tool Holders

**Milling in tight areas? Need extra long reach?
You can mill to .1563 of your tool, with 2”
Depth.**

*Introducing the **B+W MICRO-VARIO** slim chuck
system!*

Tool holders for drilling, milling, tapping and centering tools with new and extraordinary features:

- Extremely slim
- Very smooth running, minimal vibration, absolutely no run out
- Variable combinations

You will save costs by:

- ◆ Use of standard cutting tools with Weldon shanks instead of expensive extra long tools;
- ◆ Carbide tools can be used directly on hard access and near edge bores;
- ◆ Longer tool life by very smooth running;
- ◆ Faster machine operation through higher cutting pressures and longer cutting depth.



X-TRA LONG
TOOL HOLDERS

■ **Step 1: Select your flange**

■ **Step 2: Select extension**

■ **Step 3: Select tool holders**

Step 1: Select your flange

B+W MICRO-VARIO V-Flange		
Size	Code No.	Price
BT 30	31 300	135.93
BT 40	31 400	133.83
BT 50	31 500	163.81

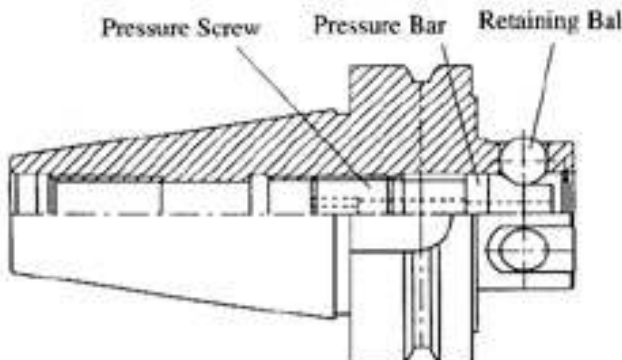

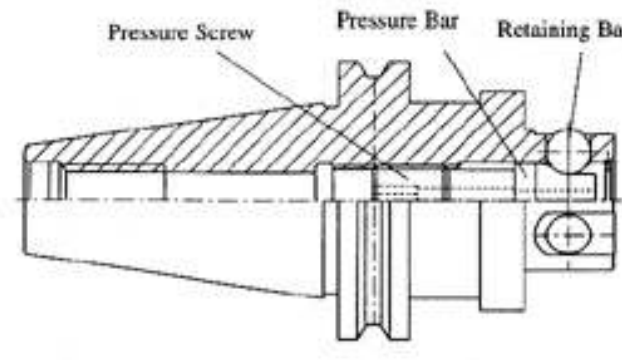

B+W MICRO-VARIO V-Flange		
Size	Code No.	Price
CAT 40	30 400	133.83
CAT 50	30 500	163.81

The Tool Holder or Extension is secured to the V-Flange by means of a hex-head thrust screw engaging a three-ball locking system. More V-Flange designs will be added in the near future. Please advise us of your needs.

Step 2: Select extension (if needed)

- ◆ A “set screw” style holder can distort the tool holder, this can cause imbalance and vibration;
- ◆ A “collet style” holder does not permit close clearance to the work;
- ◆ B + W MICRO VARIO Tool Holders overcome these problems with their unique tool holding system, which is protected by patents world wide. By securing the tool with pressure at it's center and without axial pressure, vibration is reduce to an absolute minimum.

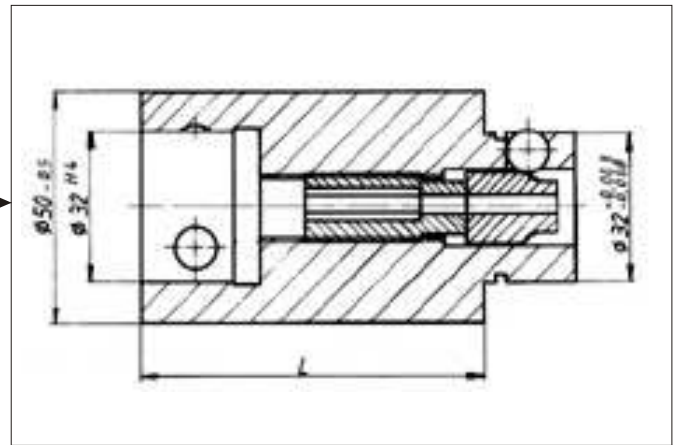

B+W MICRO-VARIO EXTENSION		
Length	Code No.	Price
50 mm	35 050	167.29
75 mm	35 075	170.78
100 mm	35 100	174.26
125 mm	35 125	177.75

The optional extensions provide added reach when needed and are removed if not needed. You have flexibility both in length and side clearance.

The B+W Micro-Vario Tool Holders are available in both fractional and metric sizes. More sizes are available; please inform us of your requirements.

Step 3: Select Tool Holders you want to have on hand

You will serve your customers much faster by:

- ◆ short delivery times and reliability of delivery, since standard tools are quickly available.

You are supplying outstanding quality at low costs and in short time by:

- ◆ high accuracy and
- ◆ better surface quality through very smooth running without chatter.

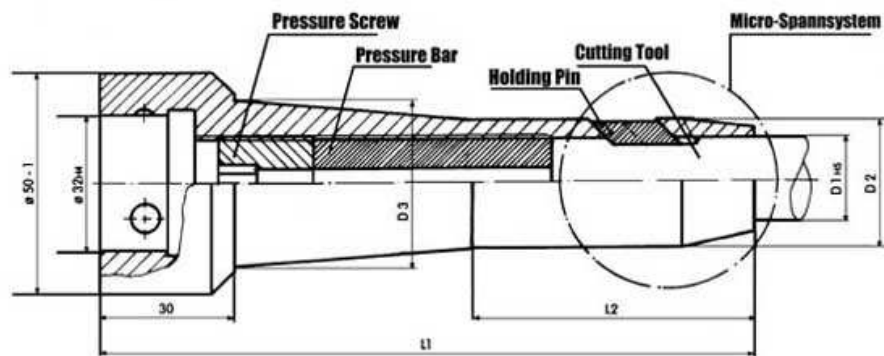

B+W MICRO-VARIO TOOL HOLDER

Size	Code No.	D1	D2	D3	L1	L2	Price
3/8 x 75 mm	41 075	0.375	0.6693	0.6693	2.9528	1.7717	141.50
3/8 x 125 mm	41 125	0.375	0.6693	1.1811	4.9213	1.7717	190.30
3/8 x 175 mm	41 175	0.375	0.6693	1.4173	6.8898	1.7717	208.42
1/2 x 75 mm	42 075	0.500	0.7874	0.7874	2.9528	1.9685	148.47
1/2 x 125 mm	42 125	0.500	0.7874	1.4173	4.9213	1.9685	207.72
1/2 x 175 mm	42 175	0.500	0.7874	1.5748	6.8898	1.9685	226.54
6 mm x 75 mm	43 075	6 mm	12 mm	12 mm	75 mm	40 mm	141.50
6 mm x 125 mm	43 125	6 mm	12 mm	24 mm	125 mm	40 mm	199.36
8 mm x 75 mm	44 075	8 mm	14 mm	14 mm	75 mm	44 mm	141.50
8 mm x 125 mm	44 125	8 mm	14 mm	28 mm	125 mm	44 mm	190.30
12 mm x 80 mm	46 080	12 mm	20 mm	20 mm	80 mm	50 mm	148.47
12 mm x 140 mm	46 140	12 mm	20 mm	36 mm	140 mm	50 mm	207.72